



The Ultimate in Fall Protection

flexiguard

**Adjustable Jib Boom
Fall Arrest System**

Model Numbers: (8530540, 8530586, and Items in Figure 1)

INSTRUCTION MANUAL

1

1	A	B	C
8530557	10 ft (3 m)	16 ft (4.9 m)	6.5 ft (2 m)
8530558	13 ft (4 m)	20 ft (6 m)	6.5 ft (2 m)
8530559	15 ft (4.6 m)	25 ft (7.6 m)	6.5 ft (2 m)

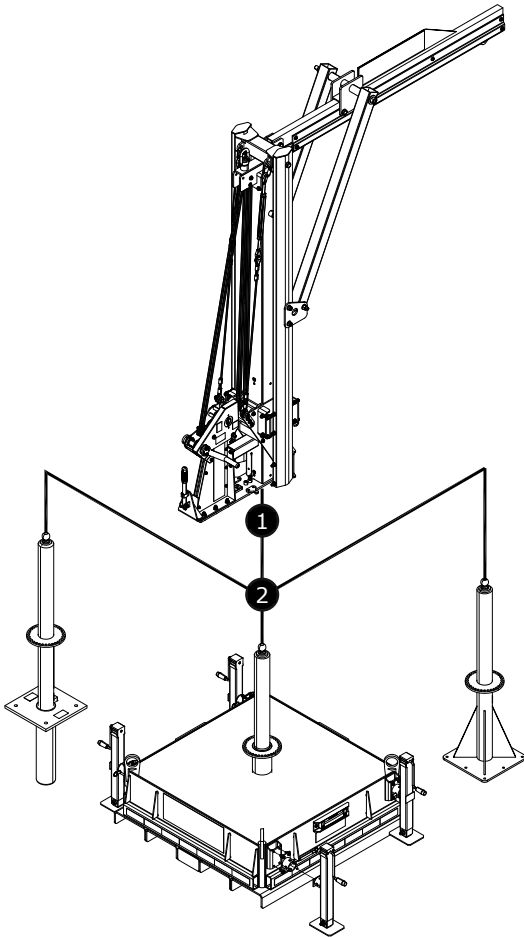

2

8530565

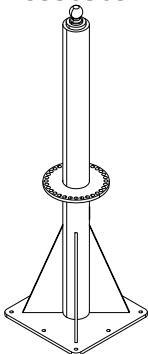

8530564

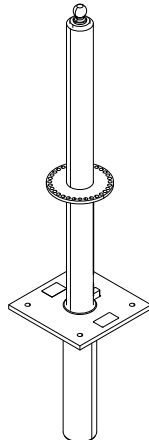

8530566

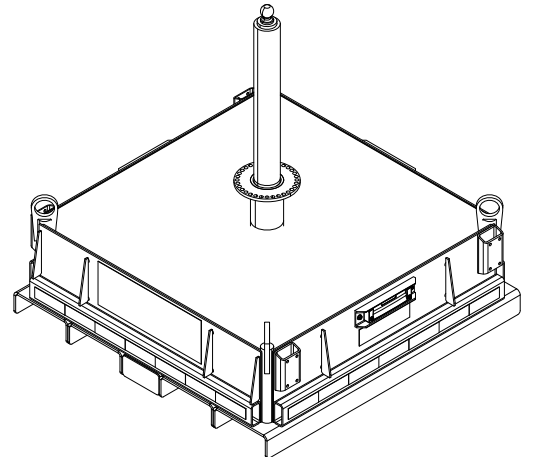

5,000 lb (2,268 kg)

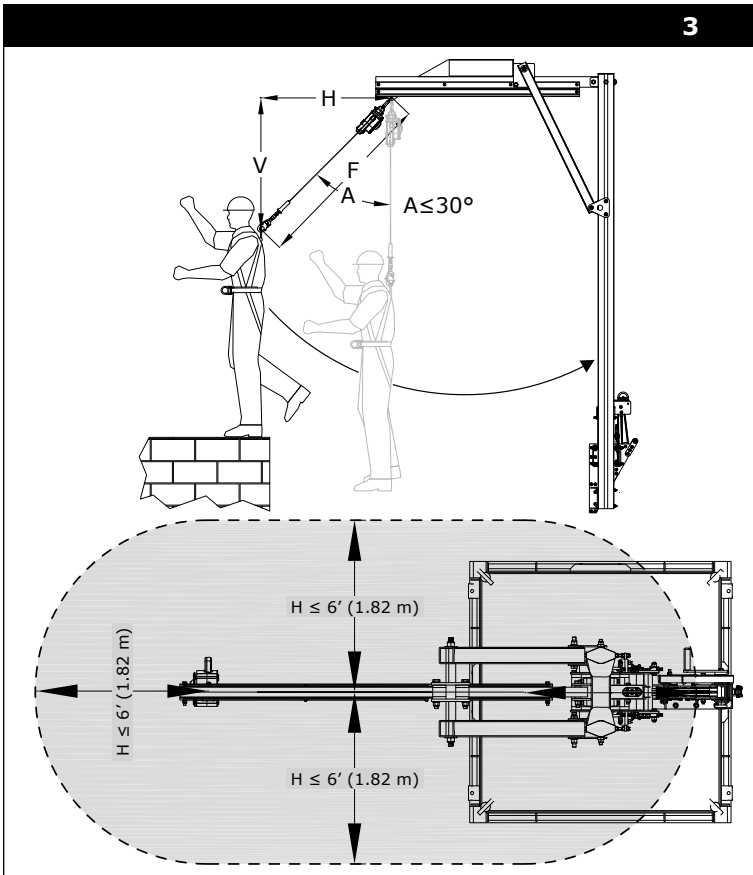

F ft (m)	← H - ft (m) →						
	0 (0.0)	1 (0.3)	2 (0.6)	3 (0.9)	4 (1.2)	5 (1.5)	6 (1.8)
0 (0.0)	0.0 (0.0)	1.0 (0.3)	2.0 (0.6)	3.0 (0.9)	4.0 (1.2)	5.0 (1.5)	6.0 (1.8)
1 (0.3)	1.0 (0.3)	1.4 (0.4)	2.2 (0.7)	3.2 (1.0)	4.1 (1.3)	5.1 (1.6)	6.1 (1.9)
2 (0.6)	2.0 (0.6)	2.2 (0.7)	2.8 (0.9)	3.6 (1.1)	4.5 (1.4)	5.4 (1.6)	6.3 (1.9)
3 (0.9)	3.0 (0.9)	3.2 (1.0)	3.6 (1.1)	4.2 (1.3)	5.0 (1.5)	5.8 (1.8)	6.7 (2.0)
4 (1.2)	4.0 (1.2)	4.1 (1.3)	4.5 (1.4)	5.0 (1.5)	5.7 (1.7)	6.4 (2.0)	7.2 (2.2)
5 (1.5)	5.0 (1.5)	5.1 (1.6)	5.4 (1.6)	5.8 (1.8)	6.4 (2.0)	7.1 (2.2)	7.8 (2.4)
6 (1.8)	6.0 (1.8)	6.1 (1.9)	6.3 (1.9)	6.7 (2.0)	7.2 (2.2)	7.8 (2.4)	8.5 (2.6)
7 (2.1)	7.0 (2.1)	7.1 (2.2)	7.3 (2.2)	7.6 (2.3)	8.1 (2.5)	8.6 (2.6)	9.2 (2.8)
8 (2.4)	8.0 (2.4)	8.1 (2.5)	8.2 (2.5)	8.5 (2.6)	8.9 (2.7)	9.4 (2.9)	10.0 (3.0)
9 (2.7)	9.0 (2.7)	9.1 (2.8)	9.2 (2.8)	9.5 (2.9)	9.8 (3.0)	10.3 (3.1)	10.8 (3.3)
10 (3.0)	10.0 (3.0)	10.0 (3.1)	10.2 (3.1)	10.4 (3.2)	10.8 (3.3)	11.2 (3.4)	11.7 (3.6)
11 (3.4)	11.0 (3.4)	11.0 (3.4)	11.2 (3.4)	11.4 (3.5)	11.7 (3.6)	12.1 (3.7)	12.5 (3.8)
12 (3.7)	12.0 (3.7)	12.0 (3.7)	12.2 (3.7)	12.4 (3.8)	12.6 (3.9)	13.0 (4.0)	13.4 (4.1)
13 (4.0)	13.0 (4.0)	13.0 (4.0)	13.2 (4.0)	13.3 (4.1)	13.6 (4.1)	13.9 (4.2)	14.3 (4.4)
14 (4.3)	14.0 (4.3)	14.0 (4.3)	14.1 (4.3)	14.3 (4.4)	14.6 (4.4)	14.9 (4.5)	15.2 (4.6)
15 (4.6)	15.0 (4.6)	15.0 (4.6)	15.1 (4.6)	15.3 (4.7)	15.5 (4.7)	15.8 (4.8)	16.2 (4.9)
16 (4.9)	16.0 (4.9)	16.0 (4.9)	16.1 (4.9)	16.3 (5.0)	16.5 (5.0)	16.8 (5.1)	17.1 (5.2)
17 (5.2)	17.0 (5.2)	17.0 (5.2)	17.1 (5.2)	17.3 (5.3)	17.5 (5.3)	17.7 (5.4)	18.0 (5.5)
18 (5.5)	18.0 (5.5)	18.0 (5.5)	18.1 (5.5)	18.2 (5.6)	18.4 (5.6)	18.7 (5.7)	19.0 (5.8)
19 (5.8)	19.0 (5.8)	19.0 (5.8)	19.1 (5.8)	19.2 (5.9)	19.4 (5.9)	19.6 (6.0)	19.9 (6.1)
20 (6.1)	20.0 (6.1)	20.0 (6.1)	20.1 (6.1)	20.2 (6.2)	20.4 (6.2)	20.6 (6.3)	20.9 (6.4)
21 (6.4)	21.0 (6.4)	21.0 (6.4)	21.1 (6.4)	21.2 (6.5)	21.4 (6.5)	21.6 (6.6)	21.8 (6.7)
22 (6.7)	22.0 (6.7)	22.0 (6.7)	22.1 (6.7)	22.2 (6.8)	22.4 (6.8)	22.6 (6.9)	22.8 (7.0)
23 (7.0)	23.0 (7.0)	23.0 (7.0)	23.1 (7.0)	23.2 (7.1)	23.3 (7.1)	23.5 (7.2)	23.8 (7.2)
24 (7.3)	24.0 (7.3)	24.0 (7.3)	24.1 (7.3)	24.2 (7.4)	24.3 (7.4)	24.5 (7.5)	24.7 (7.5)
25 (7.6)	25.0 (7.6)	25.0 (7.6)	25.1 (7.6)	25.2 (7.7)	25.3 (7.7)	25.5 (7.8)	25.7 (7.8)

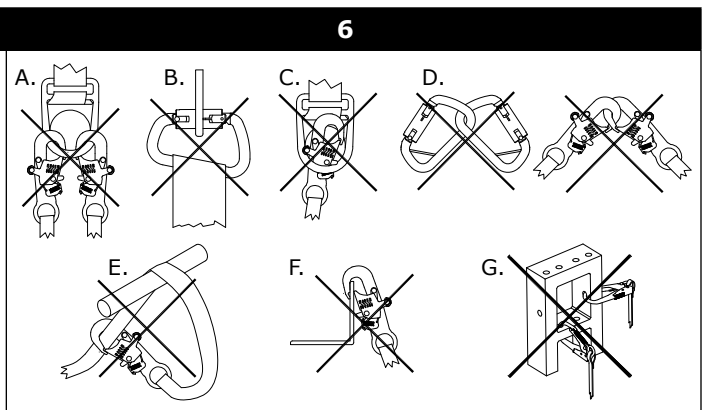
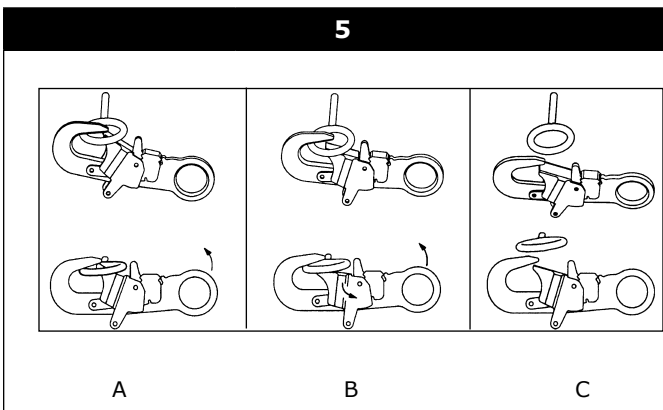
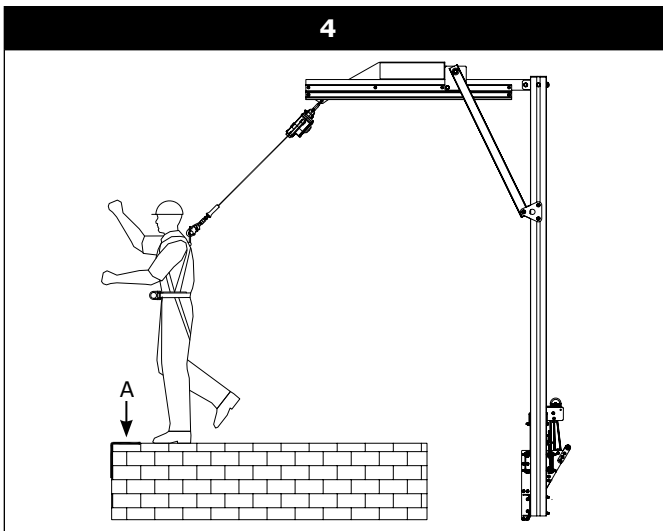

①

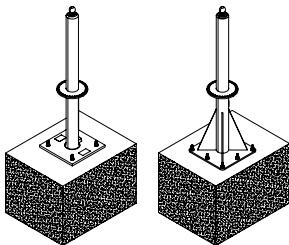

②

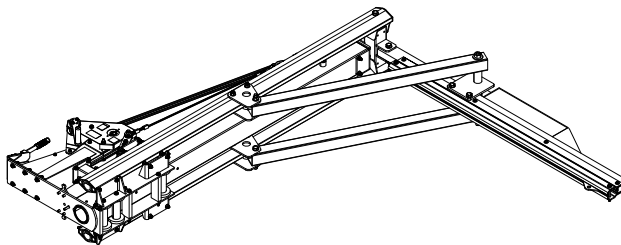

③

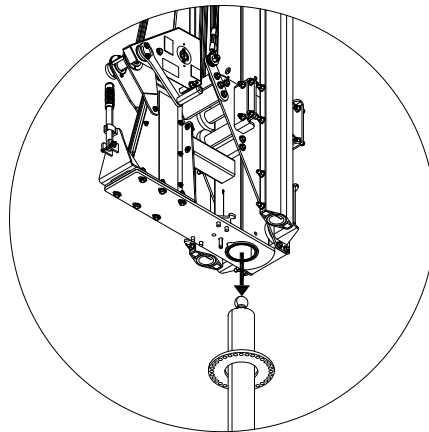
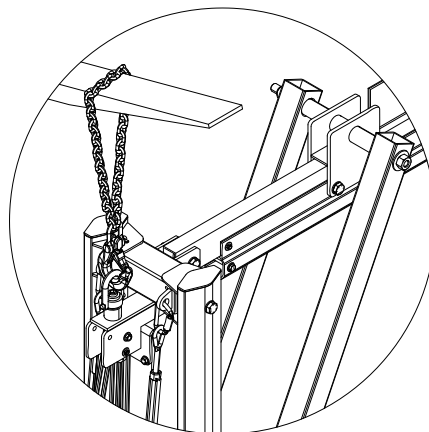
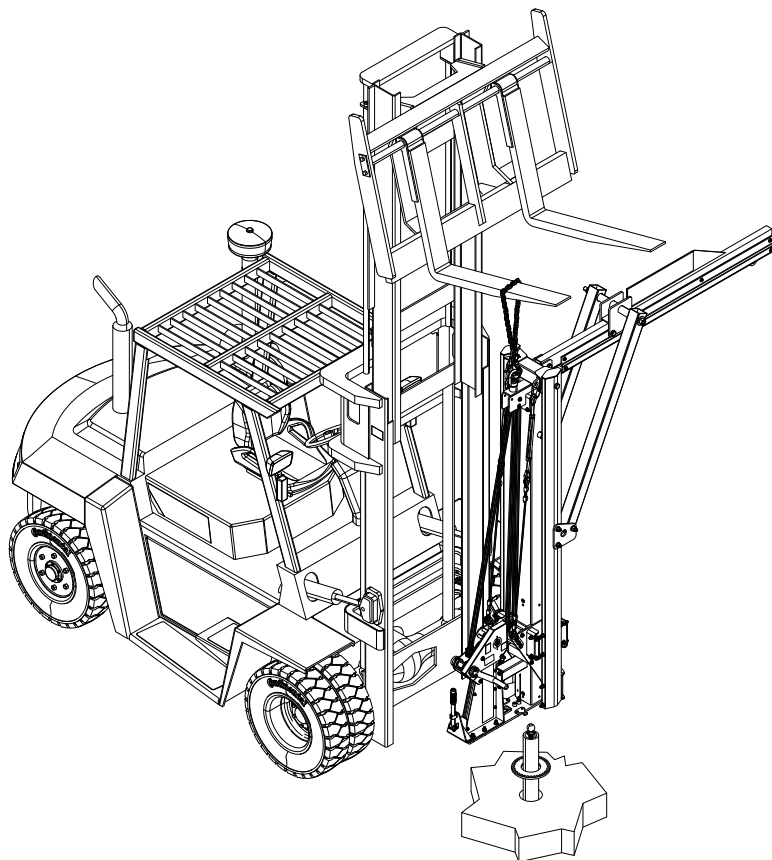

④

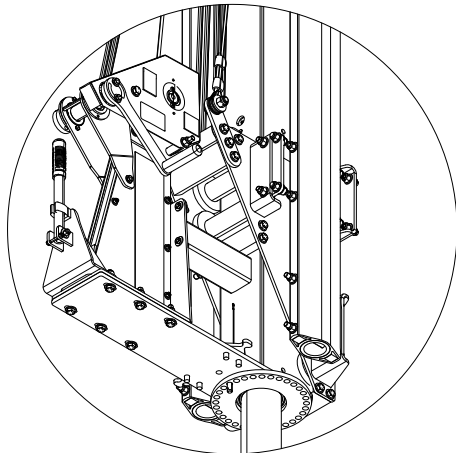

⑤

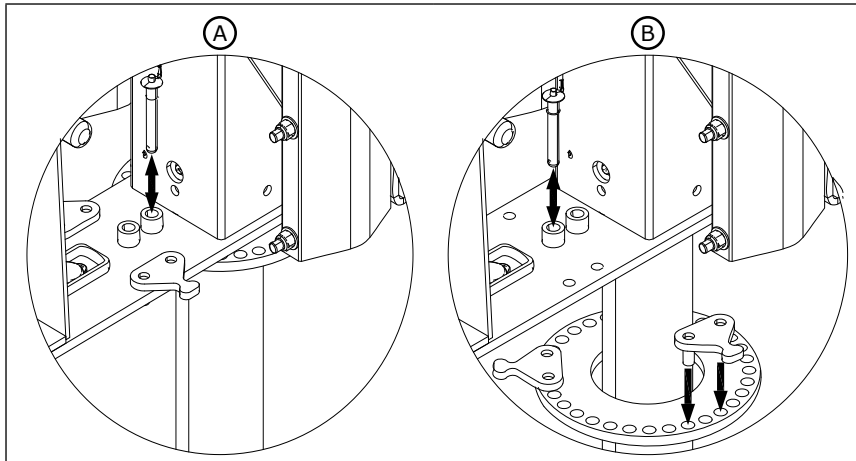

①

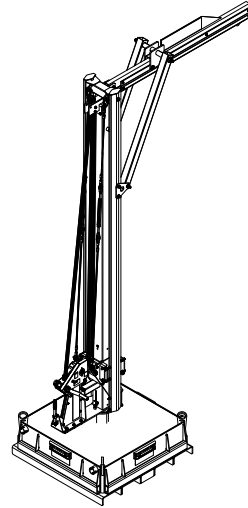
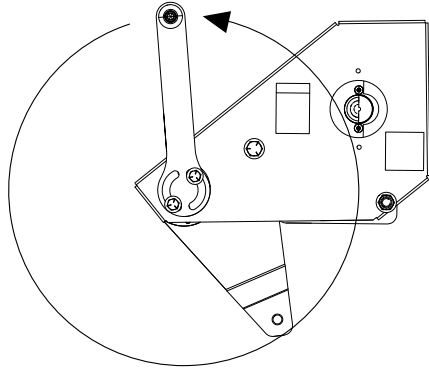
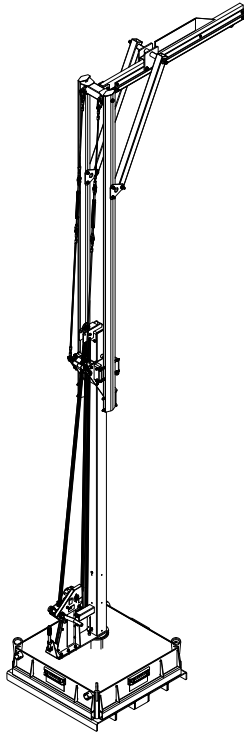

②

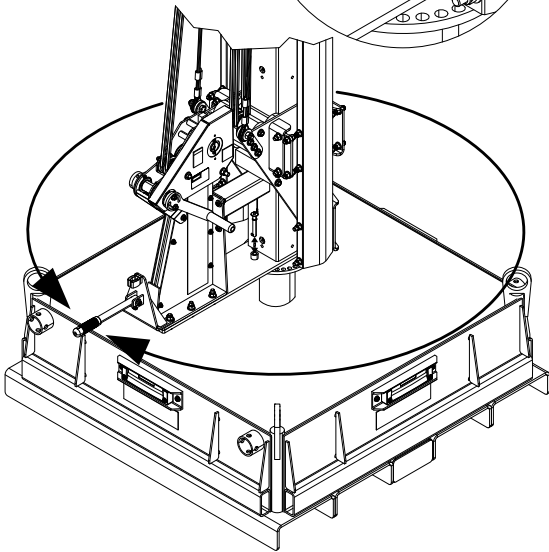
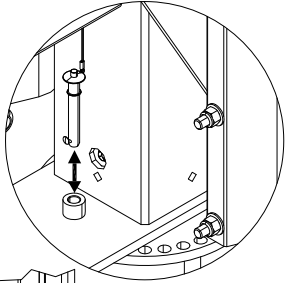

③

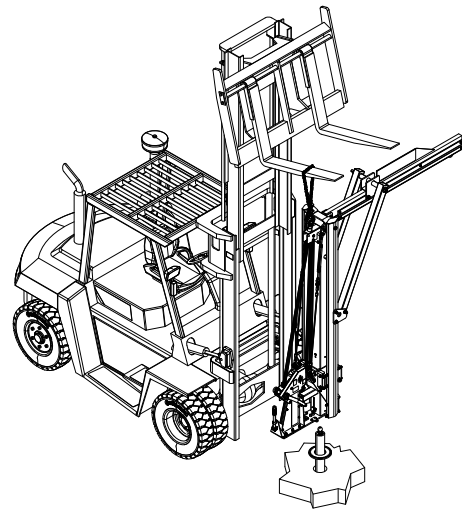
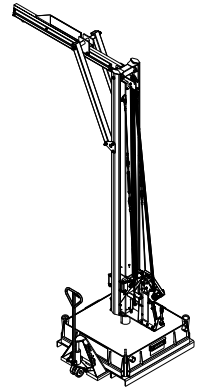
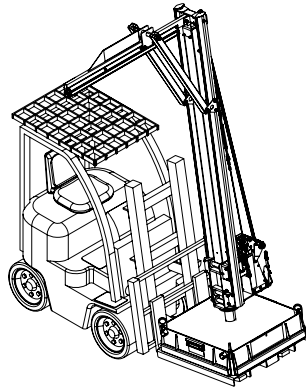

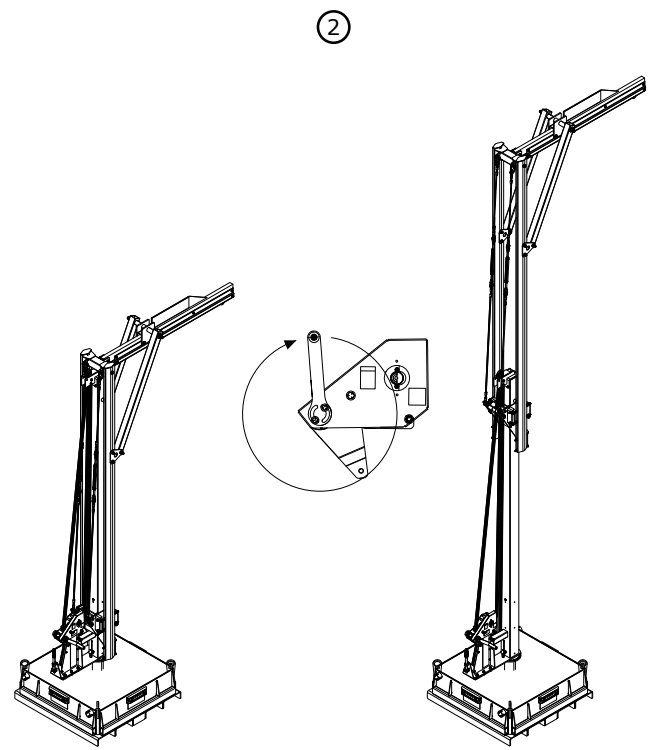
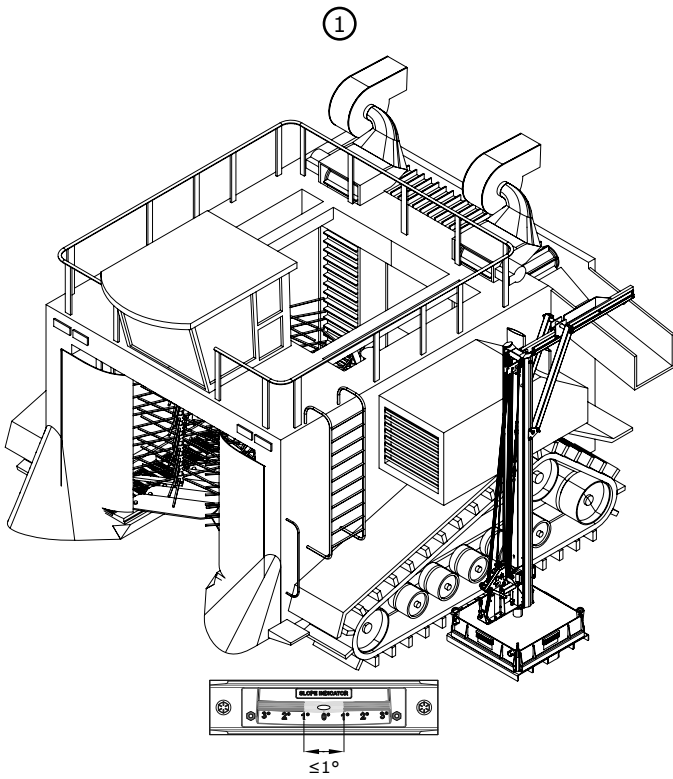

③

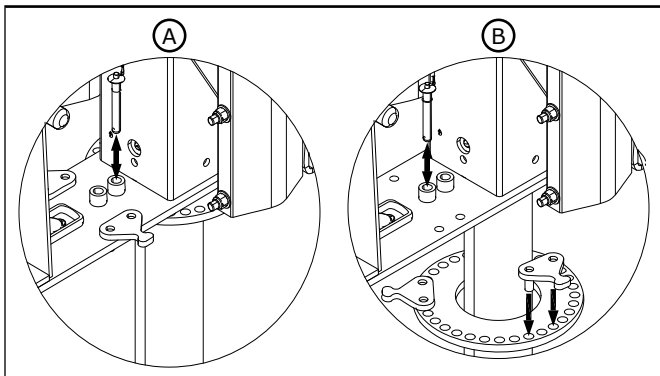
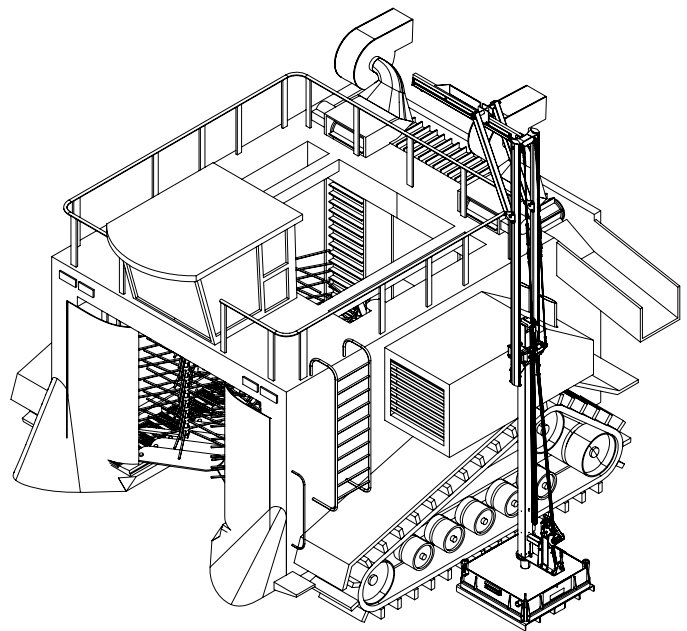
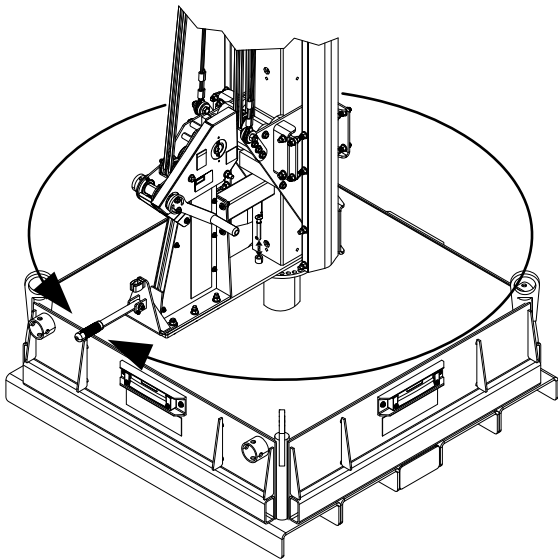

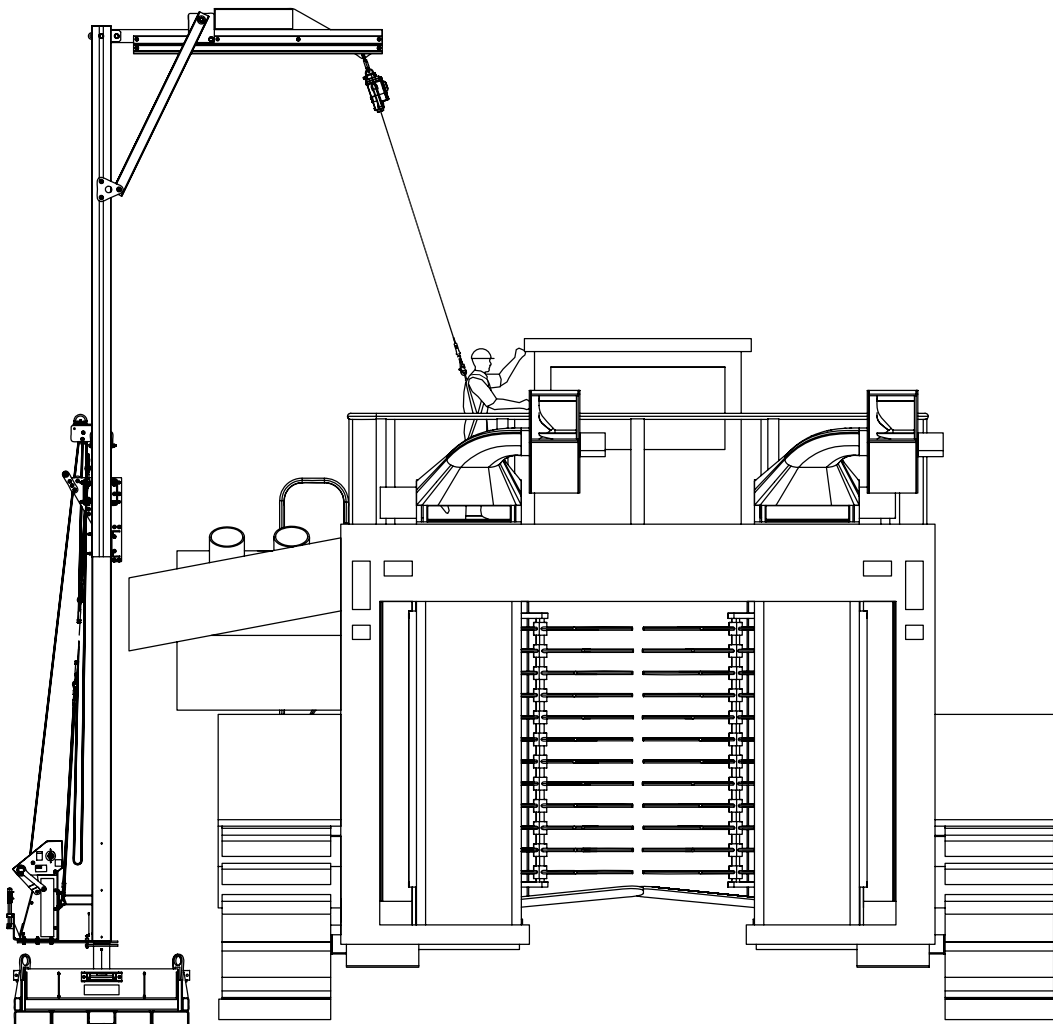
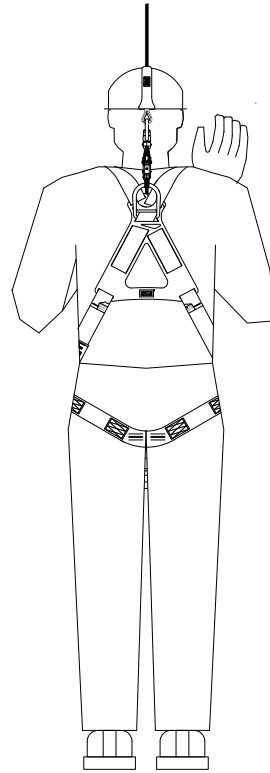
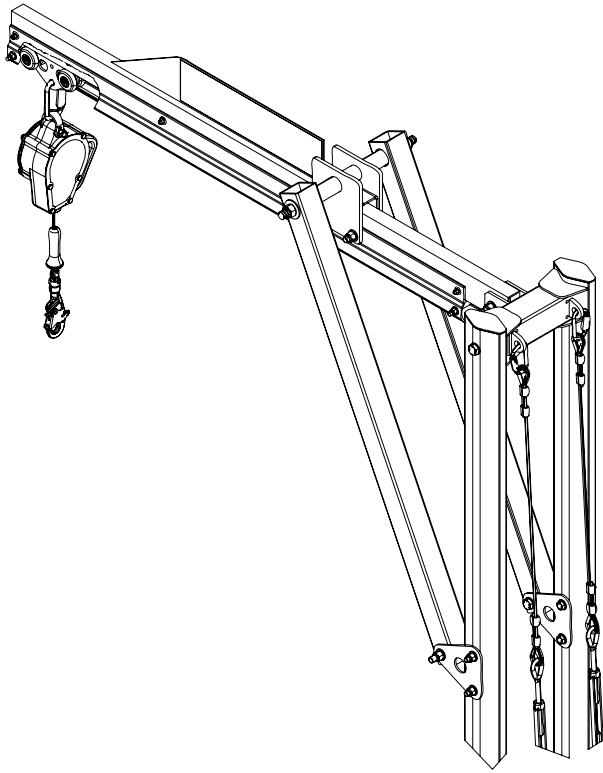

WARNING: This product is part of a Personal Fall Arrest and Work Positioning system. The user must follow the manufacturer's instructions for each component of the system. These instructions must be provided to the user of this equipment. The user must read and understand these instructions before using this equipment. Manufacturer's instructions must be followed for proper use and maintenance of this equipment. Alterations or misuse of this product or failure to follow instructions may result in serious injury or death.

IMPORTANT: If you have questions on the use, care, or suitability of this equipment for your application, contact Capital Safety. For general questions, refer to national Standards including the ANSI Z359 (.0, .1, .2, .3, and .4) family of standards on fall protection, ANSI A10.32, and applicable local, state, and federal (OSHA) requirements governing occupational safety for more information about fall protection systems.

IMPORTANT: Prior to installation and use of this equipment, record the product identification information from the ID label in the Inspection and Maintenance Log (Table 2) at the back of this manual.

PRODUCT DESCRIPTION:

Figure 1 illustrates the Flexiguard® Adjustable Jib Boom Fall Arrest Systems. The Adjustable Jib Booms are adjustable height boom mounted Glide Rail Fall Arrest Systems that rotate 360° on various base options. Systems with a Counterweight Base can be transported with a Forklift, Pallet Jack, Crane, etc. Systems with a stationary Flush Mount Base or Floor Mount Base can be transported from base to base with a Crane, Hoist, or Forklift with a Lifting Strap/Chain.

Figure 2 illustrates components of the Adjustable Jib Boom Fall Arrest Systems. See Table 1 for component identification and specifications. The Jib Rail Assembly (A) extends from an Adjustable Upright (B) and supports a Glide Rail (C) with a Four-Wheeled Trolley (D) that travels back and forth in the Rail Halves. The Trolley is equipped with a 5/8" Eye for connection of a Self-Retracting Lifeline or Energy Absorbing Lanyard.

The Adjustable Upright is mounted on a Hitch Ball Post (E) that is embedded in a concrete filled Counterweight Base (F), embedded in concrete structure (G), or fastened to a concrete surface (H). The height of the Jib Boom is adjusted with a Hand Crank (I) and Lifting Mechanism (J) that raise or lower the Adjustable Upright. The Adjustable Upright can be rotated 360° with the foldable Rotation Handle (K) and locked at 11° increments with the Rotation Lock Pin Mechanism (L) or allowed to rotate through a range defined by two Rotation Limiters (R). The bottom of the Counterweight Base has Lifting Channels (N) and Lifting Eyes (O) for transport with a Forklift, Pallet Jack, Crane, etc. and Slope Indicators (P) to ensure the system is level. Optional Leveling Jacks (Q) can be installed on the Counterweight Bases.

Table 1 – Specifications

Component Specifications:				
Figure 2 Reference	Component	Materials	Rating	Assembly/Install Instruction
(A)	Jib Rail Assembly	Aluminum		5903390
(B)	Adjustable Upright Assembly	Tubes - Steel Rollers - Nylatron Lifting Connection Point - Steel	Connection Point - LIFTING ONLY, not for Fall Protection: 1,200 lbs (544 kg) Vertical (↓) Load	5903390
(C)	Glide Rail	Aluminum Rail Halves	1,800 lbs (817 kg) Vertical (↓) Load	5903390
(D)	Four-Wheeled Trolley	Wheels - Nylon Bearings - Steel 5/8" Eye - Stainless Steel	5,000 lbs (2,268 kg) Vertical (↓) Load	
(E)	Hitch Ball Post	Tube - Steel Hitch Ball Pivot - Steel		
(F)	Counterweight Base: 8530556	Steel Concrete with Steel Rebar	Filled with 4,000 psi Concrete: 8530566 = 5,000 lbs (2,268 kg)	
(G)	Flush Mount Base - 8530564	Steel		5903402
(H)	Floor Mount Base - 8530565	Steel		5903387
(I)	Hand Crank	Steel		
(J)	Lifting Mechanism	Base - Aluminum Chain & Chain Cover - Steel Gears - Steel Rollers - Plastic		
(K)	Rotation Handle	Tube - Steel Hand Grip - Rubber		
(L)	Rotation Lock Pin Mechanism	Plate - Steel Pin - Zinc Plated Steel		
(M)	Lifting Channels	Steel		
(N)	Lifting Eyes	Steel	5,000 lbs (2,268 kg) Vertical (↓) Load (1,250 lbs per Eye)	
(O)	Slope Indicators	Plastic Gauge on Aluminum C-Channel		
(P)	Jack Kit - 8530563	Jack - Steel Mounting Tubes - Steel Mounting Pin - Steel	7,000 lb (3,175 kg) Top Wind Jacks	5903386
(Q)	i-Safe™ RFID Tag	Nylon, Glass	Radio Frequency - 13.56 MHz	
(R)	Rotation Limiters	Steel with Magnets		
System Specifications:				
Capacity:	1 Person per Glide Trolley with a combined weight (including clothing, tools, etc.) of no more than 420 lbs (191 kg)			
Anchorage:	Structure supporting the Fall Arrest System must withstand a 8,800 lb (39 kN) vertical load.			

1.0 PRODUCT APPLICATION

- 1.1 PURPOSE:** Flexiguard® Anchorage Systems are designed to provide anchorage connection points for a Personal Fall Arrest System (PFAS).

WARNING: Unless otherwise noted, Capital Safety equipment is designed for use with Capital Safety approved components and subsystems only. Substitution or replacement with non-approved components or subsystems may jeopardize compatibility of equipment and may affect safety and reliability of the complete system. Do not hang, lift, or support tools or equipment from the Anchorage System, or attach guy lines for antennas, phone lines, etc.

- 1.2 SUPERVISION:** Installation of this equipment must be supervised by a Qualified Person¹. Use of this equipment must be supervised by a Competent Person⁴.
- 1.3 TRAINING:** This equipment must be installed and used by persons trained in its correct application. This manual is to be used as part of an employee training program as required by OSHA. It is the responsibility of the users and installers of this equipment to ensure they are familiar with these instructions, trained in the correct care and use of this equipment, and are aware of the operating characteristics, application limitations, and consequences of improper use of this equipment.

IMPORTANT: Training must be conducted without exposing the user to a fall hazard. Training should be repeated periodically.

- 1.4 RESCUE PLAN:** When using this equipment and connecting subsystem(s), the employer must have a rescue plan and the means at hand to implement and communicate that plan to users, authorized persons², and rescuers³. A trained, on-site rescue team is recommended. Team members should be provided with the equipment and techniques to perform a successful rescue. Training should be provided on a periodic basis to ensure rescuer proficiency.
- 1.5 INSPECTION FREQUENCY:** The Flexiguard Anchorage System shall be inspected by the user before each use and, additionally, by a competent person⁴ other than the user at intervals of no more than one year⁵. Inspection procedures are described in the "Inspection and Maintenance Log" (Table 2). Results of each Competent Person inspection should be recorded on copies of the "Inspection and Maintenance Log".
- 1.6 AFTER A FALL:** If the Flexiguard Anchorage System is subjected to the forces of arresting a fall, it must be removed from the field of service immediately and replaced or inspected by an Authorized Capital Safety Representative.

2.0 SYSTEM CONSIDERATIONS

- 2.1 ANCHORAGE:** Structure on which the Flexiguard Anchorage System is placed or mounted must meet the Anchorage specifications defined in Table 1.

FROM OSHA: Anchorages used for attachment of Personal Fall Arrest Systems shall be independent of any anchorage being used to support or suspend platforms, and capable of supporting at least 5,000 lbs (22 kN) per user attached, or be designed, installed, and used as part of a complete Personal Fall Arrest System which maintains a safety factor of a least 2, and is under the supervision of a qualified person.

- 2.2 PERSONAL FALL ARREST SYSTEM:** Figure 1 illustrates typical Fall Arrest applications of this Flexiguard Anchorage System. Personal Fall Arrest Systems (PFAS) used with the system must meet applicable OSHA, ANSI, state, and federal requirements. The PFAS shall incorporate a Full Body Harness and meet the following capabilities:

	Maximum Arresting Force	Maximum Free Fall Distance
PFAS with Shock Absorbing Lanyard	900 lb (4 kN)	6 ft (1.8 m)
	Arresting Force	Maximum Free Fall Distance
PFAS with Self Retracting Device	900 lb (4 kN) Maximum Arresting Force or 900 lb (4 kN) Average Arresting Force (as defined in ANSI Z359.14)	2 ft (0.61 m)

IMPORTANT: Under NO circumstances is a PFAS with a Free Fall distance greater than 6 ft (1.8 m) acceptable for use with the Flexiguard Anchorage System.

- 2.3 FALL PATH AND SRL LOCKING SPEED:** A clear path is required to assure positive locking of an SRL. Situations which do not allow for an unobstructed fall path should be avoided. Working in confined or cramped spaces may not allow the body to reach sufficient speed to cause the SRL to lock if a fall occurs. Working on slowly shifting material, such as sand or grain, may not allow enough speed buildup to cause the SRL to lock.
- 2.4 HAZARDS:** Use of this equipment in areas with environmental hazards may require additional precautions to prevent injury to the user or damage to the equipment. Hazards may include, but are not limited to: heat, chemicals, corrosive environments, high voltage power lines, explosive or toxic gases, moving machinery, sharp edges, or overhead materials that may fall and contact the user or Personal Fall Arrest System.

- 1 Qualified Person:** A person with a recognized degree of professional certificate and with extensive knowledge, training, and experience in the fall protection and rescue field who is capable of designing, analyzing, evaluating, and specifying fall protections and rescue systems to the extent required by OSHA and other applicable standards.
- 2 Authorized Person:** For purposes of the Z359 standards, a person assigned by the employer to perform duties at a location where the person will be exposed to a fall hazard.
- 3 Rescuer:** Person or persons other than the rescue subject acting to perform an assisted rescue by operation of a rescue system.
- 4 Competent Person:** One who is capable of identifying existing and predictable hazards in the surroundings or working conditions which are unsanitary, hazardous, or dangerous to employees, and who has authorization to take prompt corrective measures to eliminate them.
- 5 Inspection Frequency:** Extreme working conditions (harsh environments, prolonged use, etc.) may require increasing the frequency of competent person inspections.

2.5 FALL CLEARANCE: There must be sufficient clearance below the user to arrest a fall before the user strikes the ground or other obstruction. Fall Clearance is dependent on the following factors:

- Deceleration Distance
- Worker Height
- Elevation of Anchorage Connector
- Free Fall Distance
- Movement of Harness Attachment Element
- Connecting Subsystem Length

See the Personal Fall Arrest System manufacturer's instructions for specifics regarding Fall Clearance calculation.

2.6 SWING FALLS: Swing Falls occur when the anchorage point is not directly above the point where the fall occurs (see Figure 3). The force of striking an object while swinging from the pendulum effects of a Swing Fall can cause serious injury. Swing Falls can be minimized by limiting the horizontal distance (H) between the user and the anchorage point. In a Swing Fall, the total vertical fall distance (F) will be greater than if the user had fallen directly below the anchorage point, thus increasing Fall Clearance required to safely arrest the user's fall. See the PFAS manufacturer's instructions for details regarding Swing Falls and Fall Clearance calculation.

2.7 SHARP EDGES: Avoid working where Lifeline or Lanyard components of the Personal Fall Arrest System (PFAS) can contact or abrade against unprotected sharp edges (see Figure 4). Where contact with a sharp edge is unavoidable, cover the edge with protective material (A).

2.8 COMPONENT COMPATIBILITY: Capital Safety equipment is designed for use with Capital Safety approved components and subsystems only. Substitutions or replacements made with non-approved components or subsystems may jeopardize compatibility of equipment and may effect the safety and reliability of the complete system.

IMPORTANT: *Equipment substitutions require written consent from Capital Safety.*

2.9 CONNECTOR COMPATIBILITY: Connectors are considered to be compatible with connecting elements when they have been designed to work together in such a way that their sizes and shapes do not cause their gate mechanisms to inadvertently open regardless of how they become oriented. Contact Capital Safety if you have any questions about compatibility.

Connectors (hooks, carabiners, and D-rings) must be capable of supporting at least 5,000 lbs. (22.2 kN). Connectors must be compatible with the anchorage or other system components. Do not use equipment that is not compatible. Non-compatible connectors may unintentionally disengage (see Figure 5). Connectors must be compatible in size, shape, and strength. If the connecting element to which a snap hook or carabiner attaches is undersized or irregular in shape, a situation could occur where the connecting element applies a force to the gate of the snap hook or carabiner (A). This force may cause the gate to open (B), allowing the snap hook or carabiner to disengage from the connecting point (C).

Self-locking snap hooks and carabiners are required by ANSI Z359 and OSHA.

2.10 MAKING CONNECTIONS: Snap hooks and carabiners used with this equipment must be self-locking. Ensure all connections are compatible in size, shape and strength. Do not use equipment that is not compatible. Ensure all connectors are fully closed and locked.

Capital Safety connectors (snap hooks and carabiners) are designed to be used only as specified in each product's user's instructions. See Figure 6 for examples of inappropriate connections. Do not connect snap hooks and carabiners:

- A. To a D-ring to which another connector is attached.
- B. In a manner that would result in a load on the gate.

NOTE: *Large throat snap hooks should not be connected to standard size D-rings or similar objects which will result in a load on the gate if the hook or D-ring twists or rotates, unless the snap hook complies is equipped with a 3,600 lb (16 kN) gate. Check the marking on your snap hook to verify that it is appropriate for your application.*

- C. In a false engagement, where features that protrude from the snap hook or carabiner catch on the anchor, and without visual confirmation seems to be fully engaged to the anchor point.
- D. To each other.
- E. Directly to webbing or rope lanyard or tie-back (unless the manufacturer's instructions for both the lanyard and connector specifically allows such a connection).
- F. To any object which is shaped or dimensioned such that the snap hook or carabiner will not close and lock, or that roll-out could occur.
- G. In a manner that does not allow the connector to align properly while under load.

3.0 INSTALLATION

IMPORTANT: The Flexiguard® Adjustable Jib Boom must be installed by a Qualified Person and the installation must be certified by a Qualified Person as: meeting the criteria for a Certified Anchorage, or capable of supporting the potential forces that could be encountered during a fall.

IMPORTANT: Do not alter or intentionally misuse this equipment. Consult Capital Safety when installing or using this equipment in combination with components or subsystems other than those described in this manual. Some subsystems and component combinations may interfere with the operation of this equipment.

3.1 PLANNING: Plan your fall protection system prior to installation of the Flexiguard Anchorage System. Account for all factors that may affect your safety before, during, and after a fall. Consider all requirements, limitations, and specifications defined in Section 2 and Table 1.

3.2 INSTALLING THE JIB BOOM ON THE BASE: Figure 7 illustrates installation of the Jib Boom on the available Base options:

- 1. Install Stationary Bases:** Assemble and install Floor Mount or Flush Mount Base as instructed in their respective Installation Instructions (see Table 1). Counterweight Bases should come pre-assembled.
- 2. Assemble the Jib Boom:** Assemble the Jib Boom as instructed in the Assembly Instruction (see Table 1).
- 3. Position the Jib Boom over the Base:** Lift the assembled Jib Boom boom by the Hoist Ring with a Forklift or Crane. Position the Jib Boom so the Mounting Socket in the bottom of the upright is directly over the Hitch Ball Post.
- 4. Lower the Jib Boom onto the Base:** Lower the Jib Boom onto the Base until the Hitch Ball fully seats in the Mounting Socket.
- 5. Configure Jib Boom Rotation:** The Jib Boom can be locked at 11° rotation increments with the Rotation Lock Pin Mechanism or allowed to rotate through a range defined by two Rotation Limiters.
 - A. No Rotation:** Rotate the Jib Boom to the desired position and then insert the Rotation Lock Pin through the inside Pin Hole and aligned hole in the Rotation Plate to prevent the Jib Boom from rotating.
 - B. Rotation Range:** Insert the Rotation Lock Pin through the outside Pin Hole and then install Rotation Limiters on each side of the Lock Pin: Remove the Rotation Limiters from their storage positions on the Jib Boom. Insert the Rotation Limiter mounting pegs through the desired holes in the Rotation Plate to define the rotation range.

CAUTION: The Jib Boom may be used without the Rotation Lock Pin inserted, allowing 360° rotation; but can cause increased swing fall in multiple directions in the event of a fall.

3.3 INSTALLING OPTIONAL LEVELING JACKS: An optional Jack Leveling Kit is available for the Counterweight Bases. Install the Leveling Jacks on the Counterweight Base as instructed in the included Installation Instruction (see Table 1).

3.4 TRANSPORTING THE SYSTEM: Figure 8 illustrates transport of the Jib Boom. Prepare and transport the system as follows:

- 1. Lower the Jib Boom:** Turn the Vertical Adjustment Hand Crank until the Adjustable Upright and Jib Boom are fully lowered.
- 2. Rotate the Jib Boom:** Remove the Rotation Lock Pin, rotate the Jib Boom for best clearance during transport, and then reinsert the Rotation Lock Pin to prevent the Jib Boom from rotating during transport.
- 3. Transport the System:** Transport Jib Boom systems with a Counterweight Base to the desired work location with a Forklift or Pallet Jack and the Lifting Channels; or Crane or similar equipment and the Lifting Eyes on the Counterweight Base. Transport the Jib Boom from one base to another base with a Crane, Hoist or Forklift with a Lifting Strap/Chain and the Hoist Ring on the top end of the Upright Assembly.

CAUTION: Never transport the system without the Jib Boom fully lowered and the Rotation Lock Pin inserted.

WARNING: Do not transport at speeds exceeding 5 mph (8 kph). Never transport the system on slopes greater than 10°. Excessive speeds or slopes may cause system and tow vehicle tip-overs resulting in serious injury or death.

WARNING: When transporting the Jib Boom, be aware of overhead obstructions and electrical hazards which may result in serious injury or death.

1 Qualified Person: A person with a recognized degree of professional certificate and with extensive knowledge, training, and experience in the fall protection and rescue field who is capable of designing, analyzing, evaluating, and specifying fall protections and rescue systems to the extent required by OSHA and other applicable standards

3.5 POSITIONING THE SYSTEM: Figure 9 illustrates positioning and preparation of the Jib Boom for work. Position and prepare the system as follows:

- 1. Position the Jib Boom:** Place the Adjustable Jib Boom near the work area on a surface with 1° or less of slope.

SLOPE INDICATORS: The Counterweight Base is equipped with three Slope Indicators for verification of a level surface. Optional Leveling Jacks may be installed in the Leveling Jack Mounts on the Counterweight Base for purposes of leveling the Jib Boom on a surface that is not level. Extend the Leveling Jacks until they contact the ground. Crank the Leveling Jacks up or down as needed until all Slope Indicators indicate less than 1° of slope.

- 2. Raise the Jib Boom:** Turn the Vertical Adjustment Hand Crank clockwise until the Jib Rail Assembly reaches the desired height.

CAUTION: Personnel shall not be attached to the Glide Rail while the system is raised into position.

- 3. Rotate the Jib Boom:** Remove the Rotation Lock Pin and rotate the Jib Boom to the desired work position with the Rotation Handle. The Jib Boom can be locked at 11° rotation increments with the Rotation Lock Pin Mechanism or allowed to rotate through a range defined by two Rotation Limiters:

A. No Rotation: Rotate the Jib Boom to the desired position and then insert the Rotation Lock Pin through the inside Pin Hole and aligned hole in the Rotation Plate to prevent the Jib Boom from rotating.

B. Rotation Range: Insert the Rotation Lock Pin through the outside Pin Hole and then install Rotation Limiters on each side of the Lock Pin. Insert the Rotation Limiter mounting pegs through the desired holes in the Rotation Plate to define the rotation range.

CAUTION: The Jib Boom may be used without the Rotation Lock Pin inserted, allowing 360° rotation; but can cause increased swing fall in multiple directions in the event of a fall.

4.0 USE

WARNING: Consult your doctor if there is any reason to doubt your fitness to safely absorb the shock from a fall arrest or suspension. Age and fitness seriously affect a worker's ability to withstand falls. Pregnant women or minors must not use DBI-SALA equipment unless in an emergency situation.

WARNING: Never exceed the Capacity maximums specified in Table 1. Exceeding the stated capacity could collapse or tip the system, resulting in serious injury or death.

- 4.1 BEFORE EACH USE:** Verify that your work area and Personal Fall Arrest System (PFAS) meet all criteria defined in Section 2 and a formal Rescue Plan is in place. Inspect the Jib Boom per the 'User' inspection points defined on the "Inspection and Maintenance Log" (Table 2). If inspection reveals an unsafe or defective condition, do not use the Jib Boom. Remove the system from service and contact Capital Safety regarding replacement or repair.

SAFE WORK AREA: Figure 3 illustrates the Safe Work Area for the Adjustable Jib Boom. The gray shading on the table designates safe working distances where the angle of the Lifeline is less than or equal to 30° from vertical and the Horizontal Distance (H) from the anchorage connection point is less than or equal to 6 ft (1.82 m). NEVER work at a Horizontal Distance (H) and Vertical Distance (V) that results in a calculated Vertical Fall Distance (F) exceeding the gray shaded values on the table in Figure 3.

- 4.2 FALL ARREST CONNECTIONS:** Figure 10 illustrates application of the Jib Boom and its Fall Arrest Connections. The Jib Boom must always be used with a Full Body Harness and Fall Arrest subsystem. The Glide Rail System is equipped with a Four-Wheel Trolley that travels back-and-forth inside the Rail Halves. An SRL or Energy Absorbing Lanyard can be connected the Four-Wheel Trolley. Connect the other end of the SRL or Energy Absorbing Lanyard to the back Dorsal D-Ring on the Harness.

WARNING: When transferring between SRL's, always maintain 100% tie-off to ensure fall arrest protection in the event of a fall.

IMPORTANT: No more than one person, meeting the Capacity requirements specified in Table 1, shall be attached to the Glide Four-Wheel Trolley.

WARNING: Inappropriate or incompatible connections between components of the Personal Fall Arrest System (PFAS) may result in serious injury or death. See Section 2 for details regarding connector compatibility and safe connections.

5.0 INSPECTION

- 5.1 INSPECTION FREQUENCY:** The Flexiguard System must be inspected at the intervals defined in Section 1. Inspection procedures are described in the "Inspection and Maintenance Log" (Table 2). Inspect all other components of the Fall Protection System per the frequencies and procedures defined in the manufacturer's instructions.

i-Safe™ RFID: Some Flexiguard Systems are equipped with an i-Safe Radio Frequency Identification (RFID) Tag. The RFID Tag can be used in conjunction with the i-Safe Handheld Reading Device to simplify inspection and inventory control and provide records for you fall protection equipment. If you are a first-time i-Safe user, contact Capital Safety or visit www.capitalsafety.com.

- 5.2 DEFECTS:** If inspection reveals an unsafe or defective condition, remove the System from service immediately and contact Capital Safety regarding replacement or repair. Do not attempt to repair the System.

IMPORTANT: Only Capital Safety or parties authorized in writing by Capital Safety may make repairs to this equipment.

- 5.3 PRODUCT LIFE:** The functional life of the System is determined by work conditions and maintenance. As long as the product passes inspection criteria, it may remain in service.

6.0 MAINTENANCE, SERVICING, STORAGE

- 6.1 CLEANING:** Periodically clean the System's metal components with a soft brush, warm water, and a mild soap solution. Ensure parts are thoroughly rinsed with clean water.

IMPORTANT: Although highly resistant to chemicals and environmental conditions, avoid contaminating the Flexiguard System with acids, bitumen, cement, paint, cleaning fluids, etc. If the equipment contacts acids or other caustic chemicals, remove from service and wash with water and a mild soap solution. Inspect per Table 2 before returning to service.

- 6.2 SERVICE:** Only Capital Safety or parties authorized in writing by Capital Safety may make repairs to this equipment. If the Flexiguard System has been subject to fall force or inspection reveals an unsafe or defective conditions, remove the system from service and contact Capital Safety regarding replacement or repair.
- 6.3 STORAGE AND TRANSPORT:** When not in use, store and transport the System and associated fall protection equipment in a cool, dry, clean environment out of direct sunlight. Avoid areas where chemical vapors may exist. Thoroughly inspect components after extended storage.

LABELS

The following labels must be present on the Flexiguard Adjustable Counterweighted Jib Boom. Labels must be replaced if they are not fully legible. Contact Capital Safety for replacement labels.

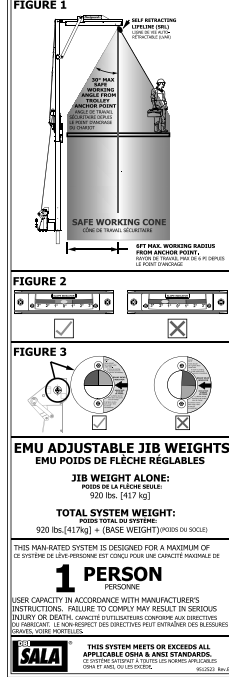
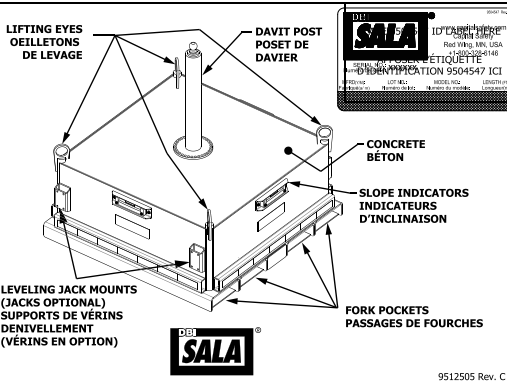
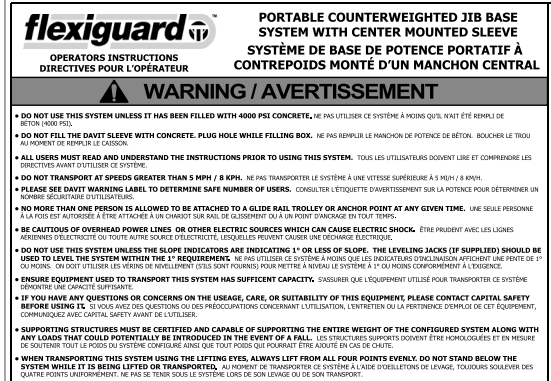
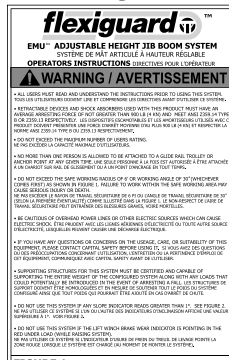
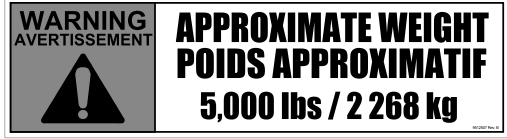
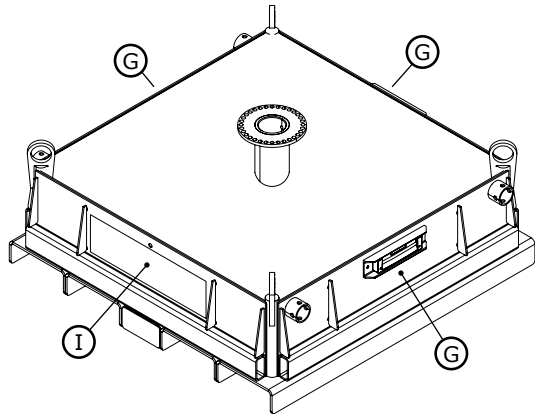
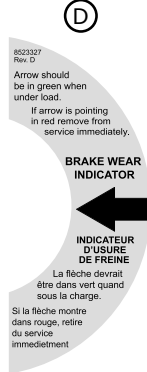
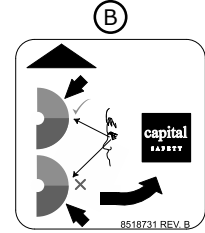
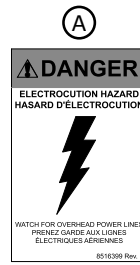
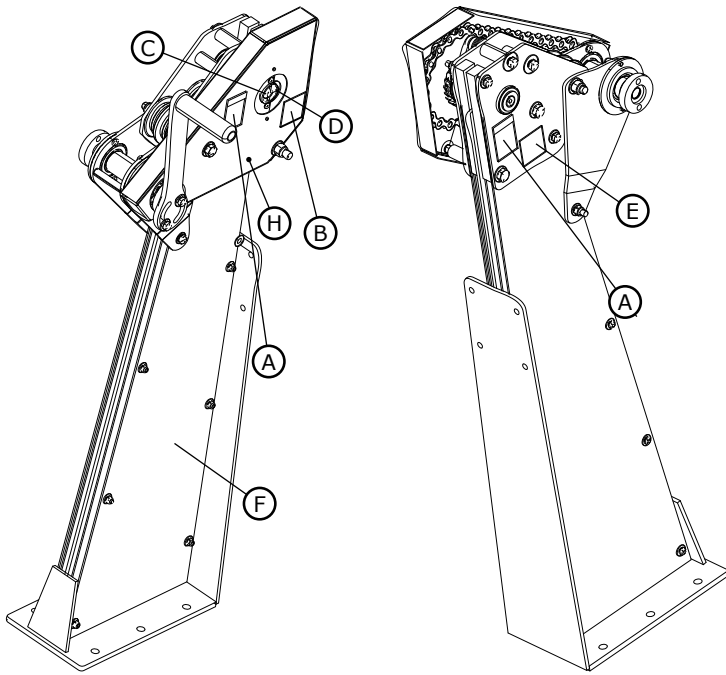

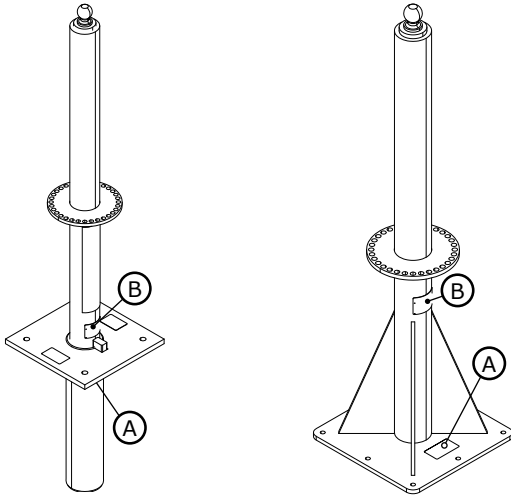

9504547 Rev. H

(A)

DBI
SALA®

www.capitalsafety.com
Capital Safety
Red Wing, MN, USA
+1-800-328-6146

SERIAL NO.: XXXXXX
Numéro de série: XXXXXX

MFRD(Y/M):	LOT NO.:	MODEL NO.:	LENGTH (FT):
Fabriqué(a/ m)	Numéro de lot:	Numéro du modèle:	Longueur(m):

(B)

! WARNING AVERTISSEMENT

YOU MUST READ AND UNDERSTAND THE OPERATOR'S MANUAL OR HAVE INSTRUCTIONS EXPLAINED TO YOU BEFORE USING THIS PRODUCT. Not following the instructions in the operator's manual can cause serious injury or death.

VOUS DEVEZ LIRE ET COMPRENDRE LE GUIDE DE L'UTILISATEUR OU VOUS FAIRE EXPLIQUER LES INSTRUCTIONS AVANT D'UTILISER CE PRODUIT. Négliger d'observer les instructions du guide de l'utilisateur peut causer des blessures graves, voire mortelles.

8515570 Rev. B

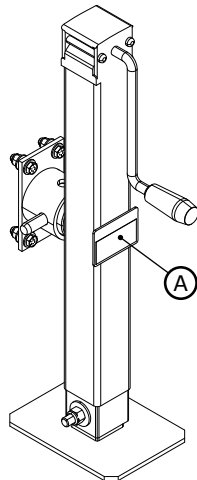

(A)

! WARNING AVERTISSEMENT

MAXIMUM LIFT CAPACITY: 5000 lbs / 22kN
Capacité maximale de portance: 5000 lbs / 22kN

Do not remove this label. Fully retract or rotate jack before towing. Engage locking pin on swivel jack before towing or using jack. Blocks used to increase height can cause instability and may cause injurt or death. Enlever pas cette etiquette. Retracter complètement la prise avant le remorquage. Engager la pin pivotent avant de remorquage ou en utilisent la prise. Blocs utilise pour augmenter la hauteur peut entrainer une instabilité et peuvent cause une blesseur our la mort.

8518723 Rev. B

Table 2 – Inspection and Maintenance Log

Inspection Date:		Inspected By:	
Components:	Inspection: (See Section 1 for <i>Inspection Frequency</i>)	User	Competent Person
Tie-Back Cable and Turnbuckle Assemblies (Diagram 1)	Inspect Turnbuckles for damage and proper adjustment.	<input type="checkbox"/>	<input type="checkbox"/>
	Check Tie-Back Cables for slack. Cables must be tight enough to apply slight pressure on the system structure, DO NOT OVERTIGHTEN. Inspect cables, for kinks (A), cut or broken wires (B), bird-caging (C), welding splatter (E), corrosion, chemical contact areas, or severely abraded areas. (see Diagram 1).	<input type="checkbox"/>	<input type="checkbox"/>
Rail Support Assemblies (Diagram 2)	Check the Rail Support (A) for structural defects or damage including bends, corrosion, etc.	<input type="checkbox"/>	<input type="checkbox"/>
	Inspect fasteners on Rail Supports to ensure they are tight.	<input type="checkbox"/>	<input type="checkbox"/>
	Visually inspect the Gussets (B) for straightness. Ensure there is no visible deformation or bend, indicating previous exposure to fall arrest forces.	<input type="checkbox"/>	<input type="checkbox"/>
Glide Rail Assembly (Diagram 3)	Visually inspect fasteners (A) on the Glide Rail to ensure they are tight.	<input type="checkbox"/>	<input type="checkbox"/>
	Inspect the Rail Track (B) for structural defects. Rail Track must be straight without any bends or dents.	<input type="checkbox"/>	<input type="checkbox"/>
	Visually inspect the Glide Four-Wheel Trolleys (C) for damage to the trolley and excessive wheel wear. Ensure the Trolleys roll freely in Glide Rail and the wheels are securely attached.	<input type="checkbox"/>	<input type="checkbox"/>
Adjustable Upright Assembly (Diagram 4)	Inspect the Adjustable Upright Assembly for defects or structural damage including bends, corrosion, etc.	<input type="checkbox"/>	<input type="checkbox"/>
	Inspect fasteners on Upright Assemblies to ensure they are tight. IMPORTANT: Do not adjust Threaded Rods (A). They are preset by the manufacturer.	<input type="checkbox"/>	<input type="checkbox"/>
	Periodically apply grease to the Grease Zerk (B) to lubricate the internal Hitch Ball Pivot		<input type="checkbox"/>
Lifting Mechanism (Diagram 5)	Inspect the Brake Wear Indicators (A) while lowering the Jib Boom. If the Brake Wear Indicator is in the Red zone (B), remove the Drive Mechanism from service and contact the manufacturer.	<input type="checkbox"/>	<input type="checkbox"/>
	Inspect fasteners on the Drive Mechanism to ensure they are tight.	<input type="checkbox"/>	<input type="checkbox"/>
	Inspect the Drive Chain (C) for slack. Deflection of the chain should not be more than 1/2 in (13 mm).	<input type="checkbox"/>	<input type="checkbox"/>
	Lubricate the Drive Chain with WD-40 (D) or a similar light lubricant.		<input type="checkbox"/>
Anchorage Connection Points	Make sure all Anchorage Connection Points are free of corrosion, cracks, or other imperfections that may cause malfunction during operation.	<input type="checkbox"/>	<input type="checkbox"/>
Labels	Verify that all labels are securely attached and are legible (see 'Labels')	<input type="checkbox"/>	<input type="checkbox"/>
PFAS and Other Equipment	Additional Personal Fall Arrest System (PFAS) equipment (harness, SRL, etc) that are used with the Flexiguard Anchorage System should be installed and inspected per the manufacturer's instructions.	<input type="checkbox"/>	<input type="checkbox"/>

Serial Number(s):	Date Purchased:
Model Number:	Date of First Use:

Corrective Action/Maintenance:	Approved By:
	Date:
Corrective Action/Maintenance:	Approved By:
	Date:
Corrective Action/Maintenance:	Approved By:
	Date:
Corrective Action/Maintenance:	Approved By:
	Date:

Diagram 1

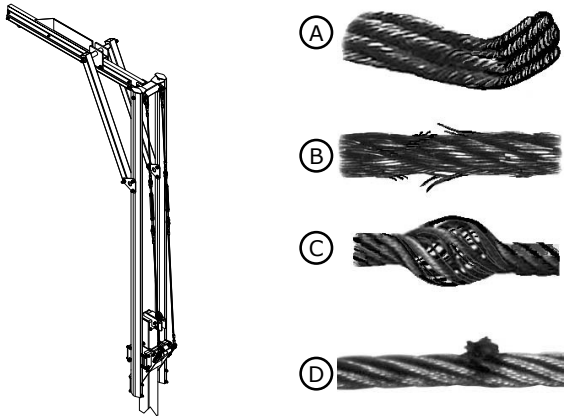

Diagram 2

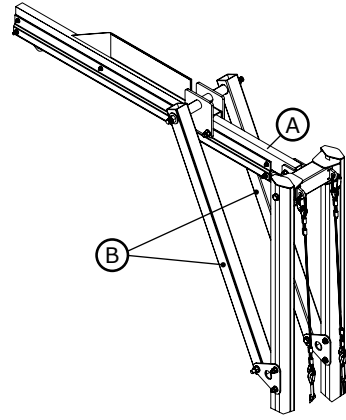

Diagram 3

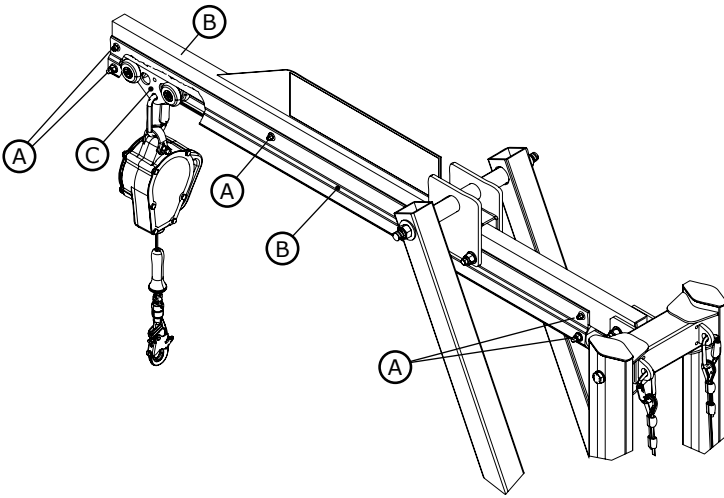

Diagram 4

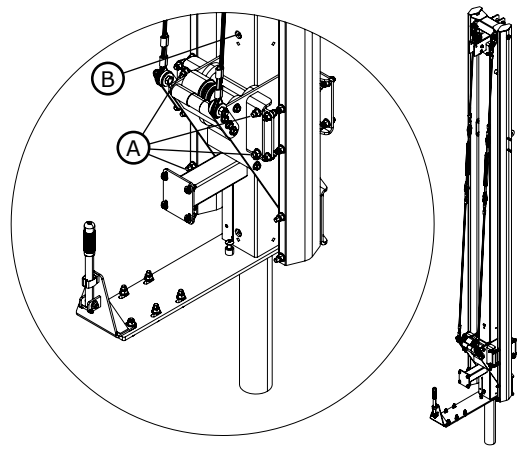
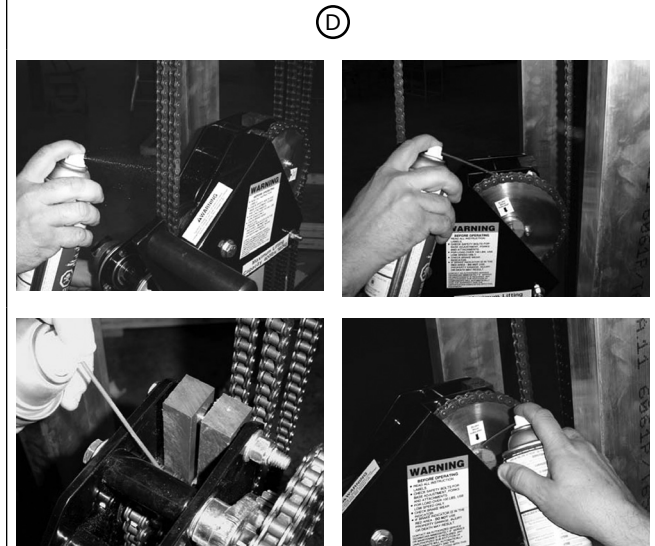
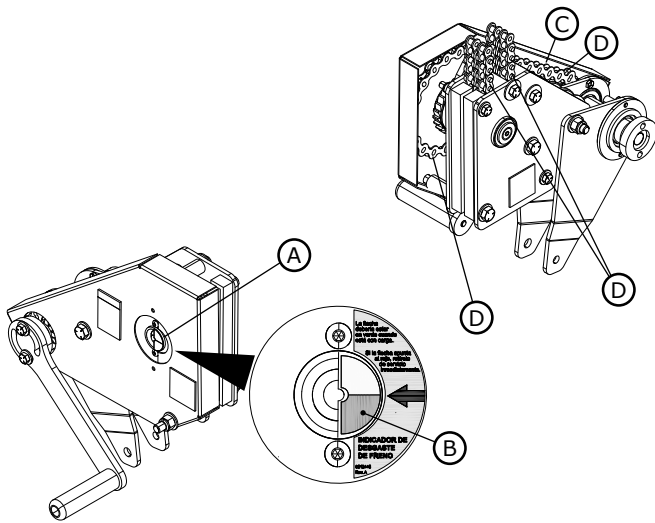

Diagram 5



LIMITED LIFETIME WARRANTY

Warranty to End User: D B Industries, Inc., dba CAPITAL SAFETY USA ("CAPITAL SAFETY") warrants to the original end user ("End User") that its products are free from defects in materials and workmanship under normal use and service. This warranty extends for the lifetime of the product from the date the product is purchased by the End User, in new and unused condition, from a CAPITAL SAFETY authorized distributor. CAPITAL SAFETY'S entire liability to End User and End User's exclusive remedy under this warranty is limited to the repair or replacement in kind of any defective product within its lifetime (as CAPITAL SAFETY in its sole discretion determines and deems appropriate). No oral or written information or advice given by CAPITAL SAFETY, its distributors, directors, officers, agents or employees shall create any different or additional warranties or in any way increase the scope of this warranty. CAPITAL SAFETY will not accept liability for defects that are the result of product abuse, misuse, alteration or modification, or for defects that are due to a failure to install, maintain, or use the product in accordance with the manufacturer's instructions.

CAPITAL SAFETY'S WARRANTY APPLIES ONLY TO THE END USER. THIS WARRANTY IS THE ONLY WARRANTY APPLICABLE TO OUR PRODUCTS AND IS IN LIEU OF ALL OTHER WARRANTIES AND LIABILITIES, EXPRESSED OR IMPLIED. CAPITAL SAFETY EXPRESSLY EXCLUDES AND DISCLAIMS ANY IMPLIED WARRANTIES OF MERCHANTABILITY OR FITNESS FOR A PARTICULAR PURPOSE, AND SHALL NOT BE LIABLE FOR INCIDENTAL, PUNITIVE OR CONSEQUENTIAL DAMAGES OF ANY NATURE, INCLUDING WITHOUT LIMITATION, LOST PROFITS, REVENUES, OR PRODUCTIVITY, OR FOR BODILY INJURY OR DEATH OR LOSS OR DAMAGE TO PROPERTY, UNDER ANY THEORY OF LIABILITY, INCLUDING WITHOUT LIMITATION, CONTRACT, WARRANTY, STRICT LIABILITY, TORT (INCLUDING NEGLIGENCE) OR OTHER LEGAL OR EQUITABLE THEORY.



Global Leader in Fall Protection

USA

3833 SALA Way
Red Wing, MN 55066-5005
Toll Free: 800.328.6146
Phone: 651.388.8282
Fax: 651.388.5065
solutions@capitalsafety.com

Brazil

Rua Anne Frank, 2621
Boqueirão Curitiba PR
81650-020
Brazil
Phone: 0800-942-2300
brasil@capitalsafety.com

Mexico

Calle Norte 35, 895-E
Col. Industrial Vallejo
C.P. 02300 Azcapotzalco
Mexico D.F.
Phone: (55) 57194820
mexico@capitalsafety.com

Colombia

Compañía Latinoamericana de Seguridad S.A.S.
Carrera 106 #15-25 Interior 105 Manzana 15
Zona Franca - Bogotá, Colombia
Phone: 57 1 6014777
servicioalcliente@capitalsafety.com

Canada

260 Export Boulevard
Mississauga, ON L5S 1Y9
Phone: 905.795.9333
Toll-Free: 800.387.7484
Fax: 888.387.7484
info.ca@capitalsafety.com

EMEA (Europe, Middle East, Africa)

EMEA Headquarters:
5a Merse Road
North Moons Moat
Redditch, Worcestershire
B98 9HL UK
Phone: + 44 (0)1527 548 000
Fax: + 44 (0)1527 591 000
csgne@capitalsafety.com

France:

Le Broc Center
Z.I. 1re Avenue - BP15
06511 Carros Le Broc Cedex
France
Phone: + 33 04 97 10 00 10
Fax: + 33 04 93 08 79 70
information@capitalsafety.com

Australia & New Zealand

95 Derby Street
Silverwater
Sydney NSW 2128
Australia
Phone: +(61) 2 8753 7600
Toll-Free : 1800 245 002 (AUS)
Toll-Free : 0800 212 505 (NZ)
Fax: +(61) 2 8753 7603
sales@capitalsafety.com.au

Asia

Singapore:
69, Ubi Road 1, #05-20
Oxley Bizhub
Singapore 408731
Phone: +65 - 65587758
Fax: +65 - 65587058
inquiry@capitalsafety.com

Shanghai:

Rm 1406, China Venturetech Plaza
819 Nan Jing Xi Rd,
Shanghai 200041, P R China
Phone: +86 21 62539050
Fax: +86 21 62539060
inquiry@capitalsafety.cn

www.capitalsafety.com

